

The new dimension of
Positioning Solutions



A-300
Column stand

FOBA[®]

Swiss made

Holds on tight to what's valuable

Meticulousness and curiosity are two of FOBA's key virtues. But we don't just pay attention to achieving optimum precision, we also listen carefully. Because of our close partnerships, we receive valu-

able customer feedback on constantly changing user needs and wishes. Our new product range, "new dimension", incorporates these ideas and is introduced below.



Crosspiece unites quality

- Combination of safety and ergonomics
- Intuitive user-friendly operation
- Smooth positioning
- Infinitely adjustable locking mechanism
- Quick-release, quick-lock system
- Maintenance-free

Mobile stability

- Fully modular design
- Central locking brake
- Smooth movement with double swivel castor
- Straightforward assembly and disassembly
- Longevity guarantee



Pulley for precious devices

- Excellence from a single source
- Vision meets functionality
- Incredibly comfortable to use
- Combines safety and freedom of positioning



Camera plate in a new light

- Anti-rotation pin for any load
- Connection for standard 3/8" thread
- Sturdy aluminium construction
- Timeless design

Simplicity at its best

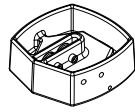

Modularity

Right from the start, FOBA saw this as a cornerstone of its business so that future customer requests would not be limited and costs would remain under control.

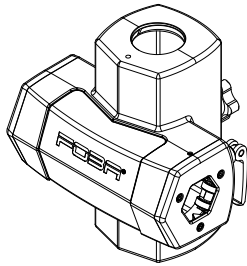

Naming system

Due to the innumerable options for configuration, a universally understandable product numbering system was developed to ensure clear and accurate handling.

Spare parts management

Maintenance of our products and expansion of existing applications in the field can be handled easily and efficiently. Each component can be reordered individually and added at a later date should the area of application change or expand.

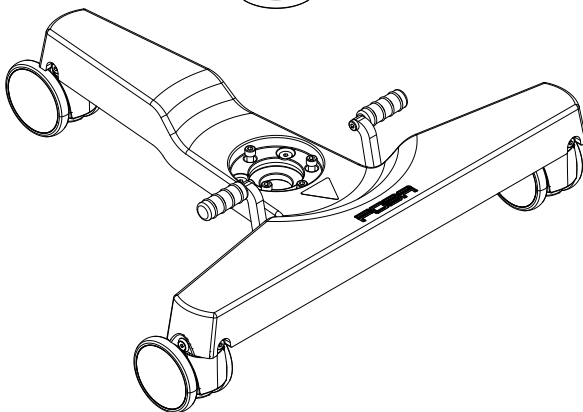
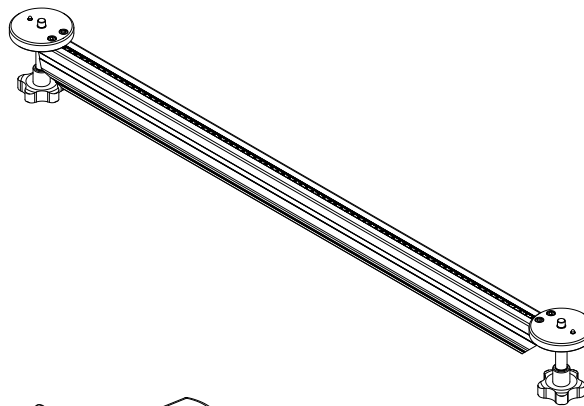
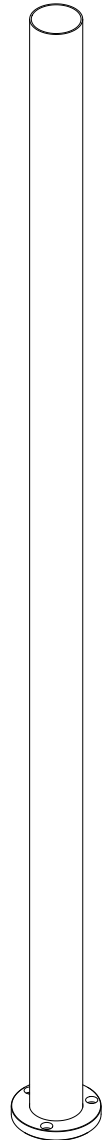

Would you like a
personal consultation?

Contact us.

FOBA AG

Friedgrabenstrasse 21
CH - 8907 Wettswil
Switzerland

Tel. +41 44 701 90 00
Fax +41 44 701 90 01

info@foba.com
www.foba.com

FOBA®